



PL-S Blacklight Blue

PL-S 9W BLB/4P 1CT/6X10CC

PL-S Blacklight Blue is a special low-wattage compact fluorescent lamp emitting long wave UV radiation for detection and analysis purposes in archaeology, money checking, forensic science, food industry, medicine, mineralogy, philately as well for special effects in night clubs, discos, theatres and sign lighting. The 2-pin version is designed for operation on electromagnetic gear, the 4-pin version is designed for operation on electronic gear. Both versions are provided with a plug-in/pull-out lamp base.

Warnings and Safety

- A lamp breaking is extremely unlikely to have any impact on your health. If a lamp breaks, ventilate the room for 30 minutes and remove the parts, preferably with gloves. Put them in a sealed plastic bag and take it to your local waste facilities for recycling. Do not use a vacuum cleaner.

Product data

General Information		Mechanical and Housing	
Cap-Base	2G7	Bulb Shape	2XT12
Useful Life (Nom)	8,000 hour(s)		
Light Technical		Approval and Application	
Color Code	108 [08 lead free glass]	Mercury (Hg) Content (Nom)	3.0 mg
Color Designation	Blacklight Blue		
Operating and Electrical		Product Data	
Power Consumption	8.6 W	Order product name	PL-S 9W BLB/4P 1CT/6X10CC
Lamp Current (Nom)	0.17 A	Full product name	PL-S 9W BLB/4P 1CT/6X10CC
Voltage (Nom)	60 V	Full product code	871150095093280
Voltage (Nom)	60 V	Order code	927901910807
		Material Nr. (12NC)	927901910807
		Numerator - Quantity Per Pack	1
		EAN/UPC - Product/Case	8711500950932
		Numerator - Packs per outer box	60

PL-S Blacklight Blue

EAN/UPC - Case

8711500950956

Dimensional drawing

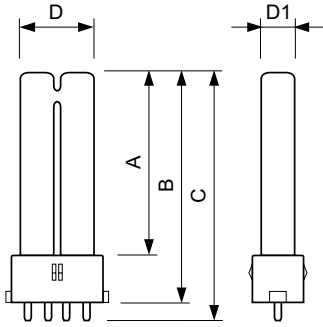

Product	D1 (max)	B (max)
PL-S 9W BLB/4P 1CT/6X10CC	13.0 mm	145.0 mm

