

Value Flex Power IP – VI06P

Datasheet



Benefit

- Energy saving low-power LED flexible strip
- Easy installation with Track
- Available in warm white and cold white
- 120° viewing angle per module
- IP66 Protection
- Dimmable

Application

- Hospitality Lighting
- Cabinet Lighting
- Signage
- Architecture lighting
- Wall integration

Technical Operating Data

Product	Color	No. of LEDs	Voltage [V DC]*	Power [W]*	Current [A]*	Radiance Angle [°]*	Wavelength Color Temp [K]*	Lum. Flux [lm]*
VI06P-W4F-830	White	300	24	68	2.85	120	3000 K	4395
VI06P-W4F-860	White	300	24	68	2.85	120	6000 K	4265

*) All Data are related to the entire module.

Due to the special conditions of the manufacturing processes of LED the typical data of technical parameters can only reflect statistical figures and do not necessarily correspond to the actual parameters of each single product which could differ from the typical data.

Technical Features

- Size of printed circuit board (L x W x H): 5000 mm x 11.1 mm x 5.5 mm
- Size of smallest unit (L x W): 99.6 mm x 11.1 mm
- The maximum LED pitch is 16.6mm
- Entire Module consists of 300 LEDs
- Linear LED strip on flexible printed circuit board with self-adhesive tape at the back allow for easy mounting
- Up to 25,000 h lifetime for Ta < 40 °C.
- Accessory: **Value Flex Track** in 150mm and 1000mm are available for mounting use.

Minimum / Maximum Ratings

Product	Operating Temperature at Tc-Point [°C]*	Storage Temperature [°C]*	Voltage Range [V dc]*	Reverse Voltage [V dc]*
VI06P-W4F-830	-20 ... 60	-25 ... 85	23 ... 25	25
VI06P-W4F-860	-20 ... 60	-25 ... 85	23 ... 25	25

*) Exceeding maximum ratings for operating and storage temperature will reduce expected life time or destroy the LED Modules.
 Exceeding maximum ratings for operating voltage will cause hazardous overload and will likely destroy the LED Modules.
 The temperature of the LED modules must be measured at the Tc-point according to EN60598-1 in a thermally constant status with a temperature sensor or a temperature sensitive label.

Dimensions

Value Flex Power IP

VI06P

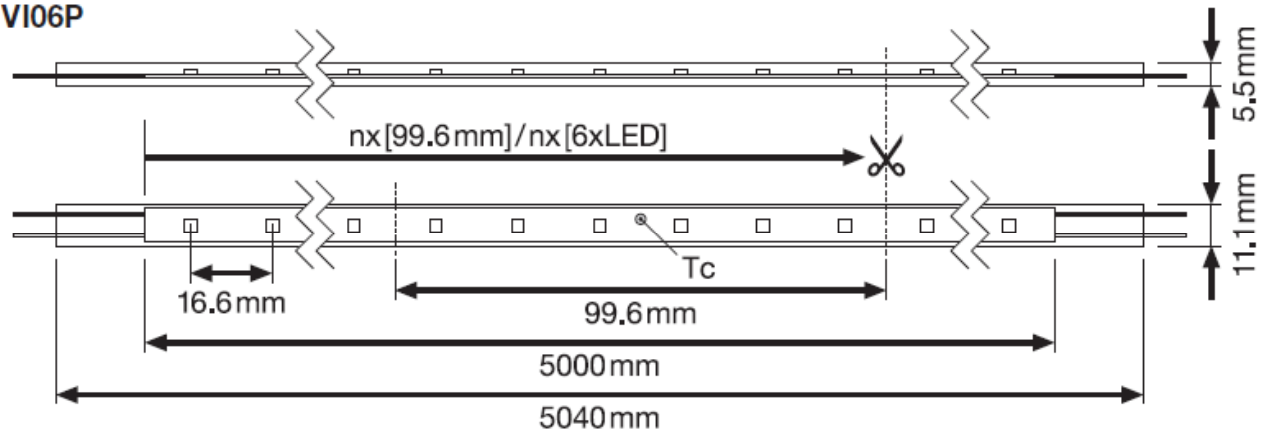

Accessory – Value Flex IP Track 150mm/1000mm

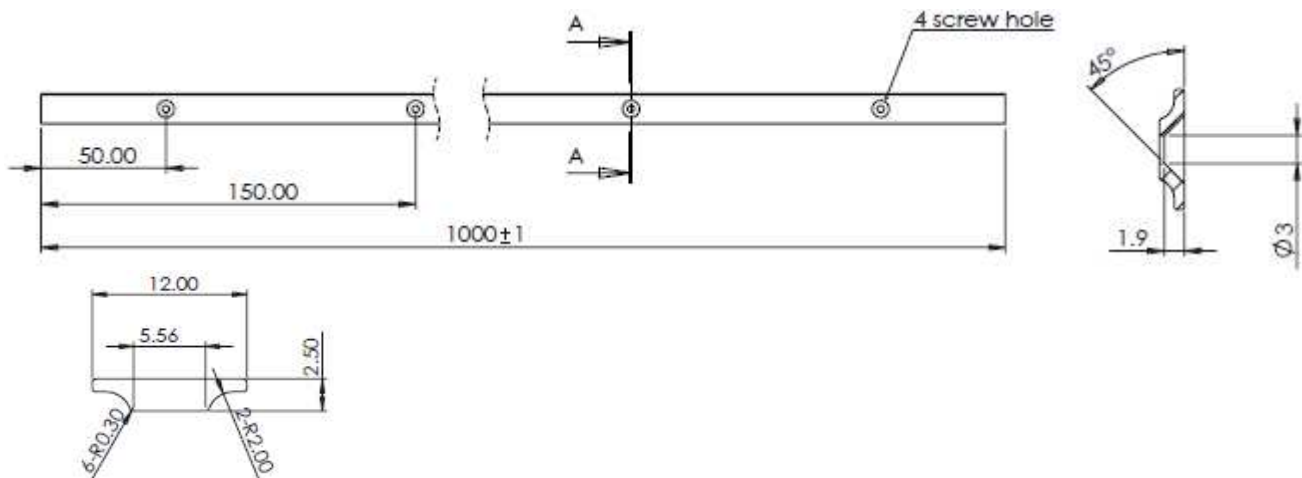

Safety Information

- The LED module itself and all its components must not be mechanically stressed.
- Assembly must not damage or destroy conducting paths on the circuit board.
- To avoid mechanical damage, the LED modules should be attached securely to the intended substrate. Heavy vibration should be avoided.

The LED module incorporates no protection against short circuits, overload or overheating.

In order to drive OSRAM LED-Modules safely, it is absolutely necessary to operate them with an electronically stabilized power supply protecting against short circuits, overload and overheating.

For dimming applications attention should be paid to specific references in "OPTOTRONIC® Technical Guide". To also ease the luminaire/installation approval, electronic control gear for LED or LED modules must carry the CE mark.

In Europe the declarations of conformity must include the following standards:

CE: EN 61347-2-13, EN 55015, EN 61547 and EN 61000-3-2.

Also check for the mark of an independent authorized certification institute.

Please see the relevant application guides for more detailed information.

When using power supplies other than OPTOTRONIC® the following basic safety features are required, in addition to any other application specific concerns and local safety codes.

OSRAM OPTOTRONIC® electronic control gear complies to all relevant standards and guarantees safe operation.

- Installation of LED modules (with power supplies) needs to be made with regard to all applicable electrical and safety standards. Only qualified personnel should be allowed to perform installations.
- Observe correct polarity! Incorrect polarity will lead to no light emission.
- Parallel connection is highly recommended as safe electrical operation mode. Serial connection is not recommended. Unbalanced voltage drop can cause hazardous overload and damage the LED module.
- OTe 90/220-240/24 E can contact 1 reels of VI06P, power feed at one end of each reel of flex.
- When mounting on metallic or otherwise conductive surfaces, there needs to be a electrical isolation at soldering points between module and the mounting surface,
- Pay attention to ESD steps when mounting the module.
- Please ensure that the power supply is of adequate power to operate the total load.
- LED modules are dimmable by means of PWM (pulse width modulation). It is recommended using the following OSRAM control gears: OPTOTRONIC® OT DIM, OT DALI DIM, OT DALI DIM LI.
- Damage by corrosion will not be honored as a materials defect claim. It is the user's responsibility to provide suitable protection against corrosive agents such as moisture and condensation and other harmful elements.

Assembly Information

- Connection with soldering wires on unmounted module: Do not pre-tin the solder pads but pre-tin the wires and solder for max 4s at 300 °C. Allow solder points to completely cool down before the next soldering. Prevent shear- or peel forces.
- Soldering of wires with the module mounted on a heat sink: Pre-tin solder pads and wires and solder for max 3s at 350 °C. Allow solder points to completely cool down before the next soldering. Prevent shear- or peel forces.
- The smallest unit (99.6 mm – 6 LEDs) can be removed by cutting with scissors between the designated solder pads.
- The mounting of the module is facilitated by means of the double-sided adhesive on the back-surface of the module. Care must be taken to provide a clean and dry mounting surface, free of oils or silicone coatings as well as dirt particle. The mounting substrate must have sufficient structural integrity. Take care to completely remove the protective backing. Once the module is appropriately positioned, press on the module with about 20N/cm² (refer to application techniques of 3M adhesive transfer tapes). In difficult cases the use of a primer may help.
- The minimum bending radius is 5cm.

Ordering Guide

Product group	Product name	EAN	S-Unit*
Value Flex Power IP 3000K	VI06P-W4F-830	4052899928718	8 pcs
Value Flex Power IP 6000K	VI06P-W4F-860	4052899928725	8 pcs
1000mm Value Flex IP Track	VI-TR1000	4008321893796	20 pcs
150mm Value Flex IP Track	VI-TR150	4008321893826	20 pcs

* EAN: Ordering number per single sale unit

* S-Unit: Modules / accessory number per shipping unit

Note: Typical performance data are subject to change without any further notice, particularly as LED technology evolves.

Sales and Technical Support

OSRAM Asia Pacific

30th Floor, China Resources Building
26 Harbour Road, WanChai, Hong Kong

www.osram.com

Sales and technical support is given by the local OSRAM subsidiaries. On our world wide homepage all OSRAM subsidiaries are listed with complete address and phone numbers.